

C.I.P.

338 Win. Mag.

Country of Origin: US

TAB. III

Date 84-06-14

Revision 02-05-15

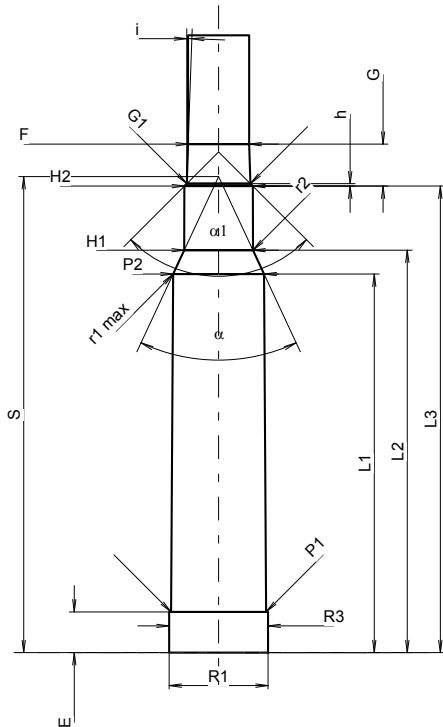
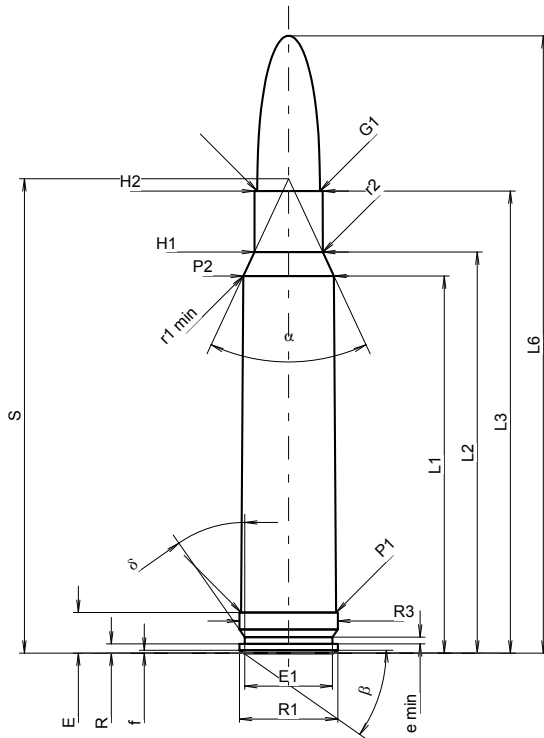

Scale 1:1.04

Dimensions in << mm >>
Dimensions and Tolerances for Proof Barrels
see Appendix CR 1.

CARTRIDGE MAXI

Lengths

L1	=	51.82
L2	=	55.11
L3 ¹⁾	=	63.50
L4	=	
L5	=	69.85
L6	=	84.84

Case Head

R	=	1.27
R1	=	13.51
R3	=	13.51
E ¹⁾	=	5.59
E1	=	12.07
e min	=	0.94
delta	=	35°
f	=	0.41
beta	=	35°

Powder Chamber

P1	=	13.03
P2 *	=	12.47

Junction Cone

alpha *	=	50°
S *	=	65.19
r1 min	=	1.02
r2	=	3.18

Collar

H1 *	=	9.40
H2 ¹⁾	=	9.37

Projectile

G1 ¹⁾	=	8.61
G2	=	8.38
F	=	
L3+G ¹⁾	=	69.27

Pressures (Energies)

Method Transducer

Pmax	=	4300 bar
PK	=	4945 bar
PE	=	5375 bar
M	=	25.00
EE	=	5460 Joule

Miscellaneous Dimensions

Fe ¹⁾	=	0.10
delta L	=	

CHAMBER MINI

Lengths

L1	=	52.02
L2	=	55.30
L3 ¹⁾	=	64.11

Breech

R	=	
R1	=	13.59
R2	=	
R3	=	13.59
r	=	

Powder Chamber

E ¹⁾	=	5.59
P1 ¹⁾	=	13.06
P2 *	=	12.50

Junction Cone

alpha *	=	50°
S *	=	65.42
r1 max	=	0.76
r2	=	3.81

Collar

H1 *	=	9.44
H2 ¹⁾	=	9.41

Commencement of Rifling

G1 ¹⁾ *	=	8.76
G ¹⁾	=	5.77
alpha1 *	=	90°
h	=	0.33
s	=	
i ¹⁾ *	=	2°
w	=	

Barrel

F ¹⁾ *	=	8.38
Z ¹⁾	=	8.59

Grooves

b	=	2.79
N	=	6
u	=	254.00
Q	=	56.95 mm ²

Notes: 1) Check for safety reasons
* Basic dimensions